

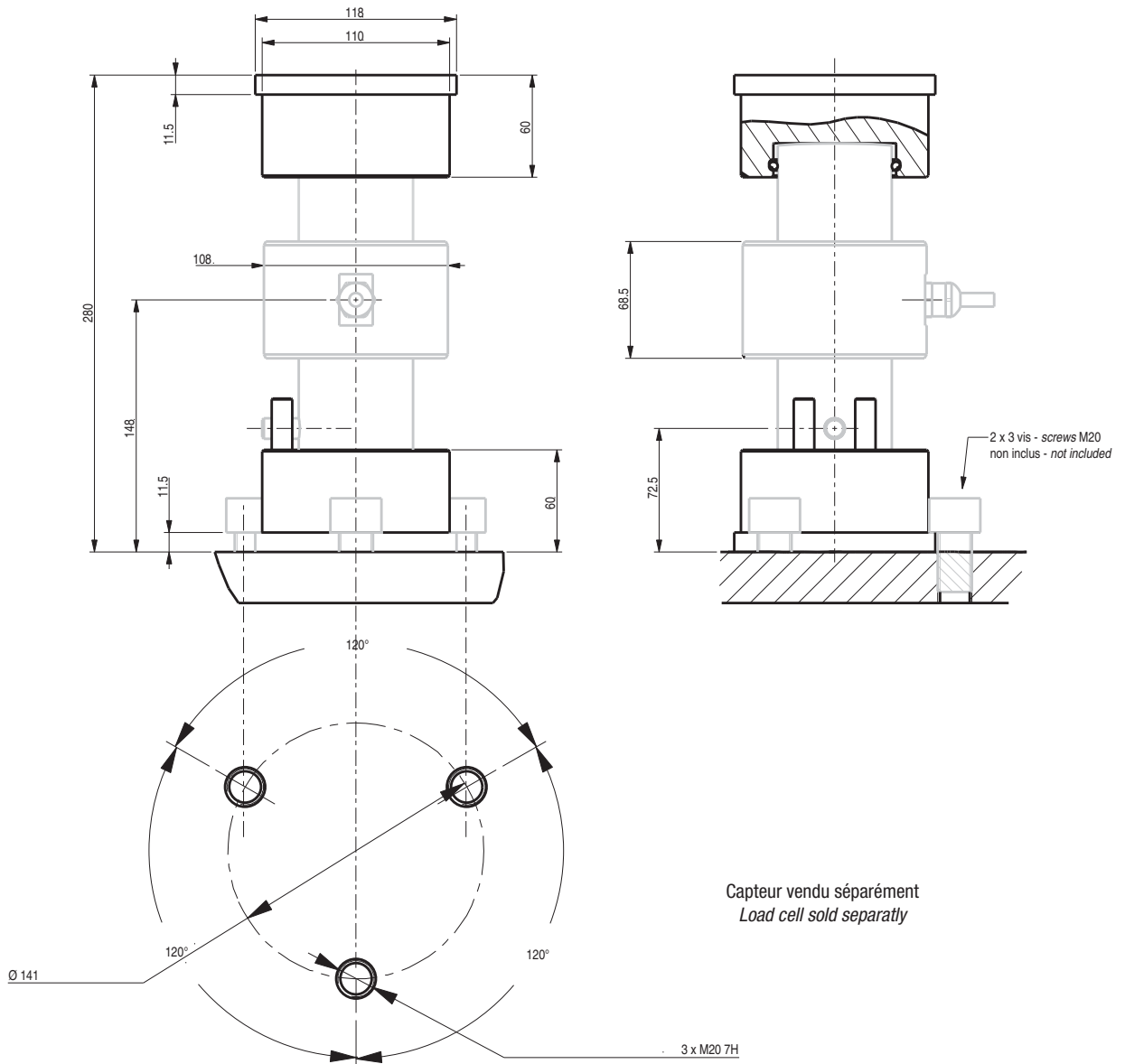

# PLAQUES

POUR - PLATES FOR CA40X 100 t ... 200 t



- Construction en acier zingué
- Utilisation avec le kit STABICAN 200 t
- Dispositif anti-rotation intégré
- Joints hermétiques sur chaque plaque

- Made of zinc plated steel
- To be used with STABICAN kit 200 t
- Integrated anti-rotated device
- Hermetic O-ring on each plate

Toutes dimensions en mm. Dimensions et spécifications non contractuelles - All dimensions in mm. Dimensions and specifications do not constitute any liability whatsoever.  
Dessins techniques disponibles sur demande - Technical drawings are available on request



BP501 - F-74105 Annemasse Cedex  
Tél. : (+33) 4 50 87 78 64  
Fax : (+33) 4 50 87 78 42  
E.mail : info@scaime.com



Téléchargez nos documents techniques.  
Download our technical documents.  
[www.scaime.com](http://www.scaime.com)

Agent