



Pressure Gauge MAN-63

Application

- hygienic pressure measurement

Application Examples

- locale display without power supply

Hygienic Design / Process Connection

- by using the Negele weld-in sleeve EMZ-352, a hygienic and easy cleanable measurement point will be achieved
- adapter for DIN 11851, Varivent, SMS, RJT etc.
- direct connection for 3/4" und 1" TriClamp
- CIP- / SIP cleanable up to 140°C / max. 60 min
- gauges completely made of stainless steel
- sensor materials and actuating fill are FDA conform
- IP66, housing for optimized cleanability

Features

- complete device is certified by 3A
- with *SMARTadapt* an easy adaption to all process connection is possible
- zero adjustable
- surface Ra<0,2µm is standard

Options

- case filling with glycerin for damping
- actuating fill with neobee M20



DIRECTadapt



MAN-63-tc 3/4"



MAN-63-tc 1"



MAN-63-s

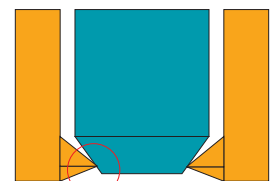

hygienic elastomer free sealing principle

Specification

Material	diaphragm	1.4404 (316L)	Over-range capability	min. 25% over range			
	fitting	1.4404 (316L)		Repeatability	±0,5% of full scale		
	Bourdon tube	1.4301 (304)			Linearity	±0,5% of full scale	
	movement	1.4301 (304)				Hysteresis	±0,5% of full scale
	case	1.4301 (304)		Temperature	process		-5°C...120°C
	inspection window	polycarbonat			CIP / SIP	140°C / max. 60min	
	case fill	glycerin			ambient	-10°C...50°C*	
Actuating fill		paraffin oil	Stability	from 10-90% of range <±0.01%/K f.s.			
	option	neobee M20 (all FDA conform)		in process or ambient temp.			
Protection class		IP66	*slower reaction at deep temperatures				

Order Code

Type	Process connection	Range	Actuating fill	Damping	Connection
MAN-63	s (CLEANadapt G1" hygienic)	-1...+2bar	paraffin oil* gc (neobee M20)	without fill* gz (glycerin fill)	u bottom*
	tc 3/4" (TriClamp3/4")	-1...+4bar			l left**
	tc1" (TriClamp 1"/1,5")	0...+2bar			r right**
		0...+4bar			
		0...+7bar			
		0...+11bar			
Order example:	MAN-63 / s / -1...+2bar / gc				

* standard, no declaration needed
** not possible with glycerin fill!



Drawings MAN-63-tc DIRECTadapt

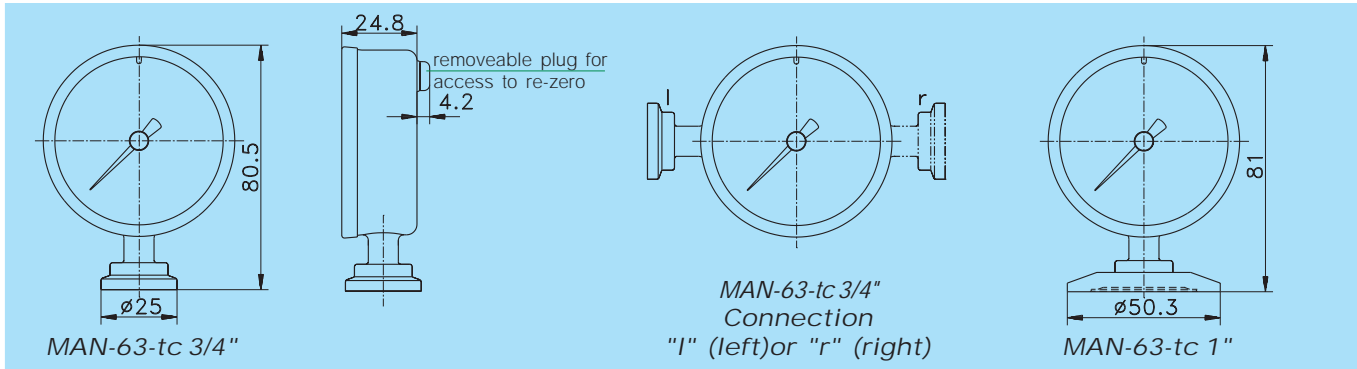

Drawings MAN-63-s CLEANadapt

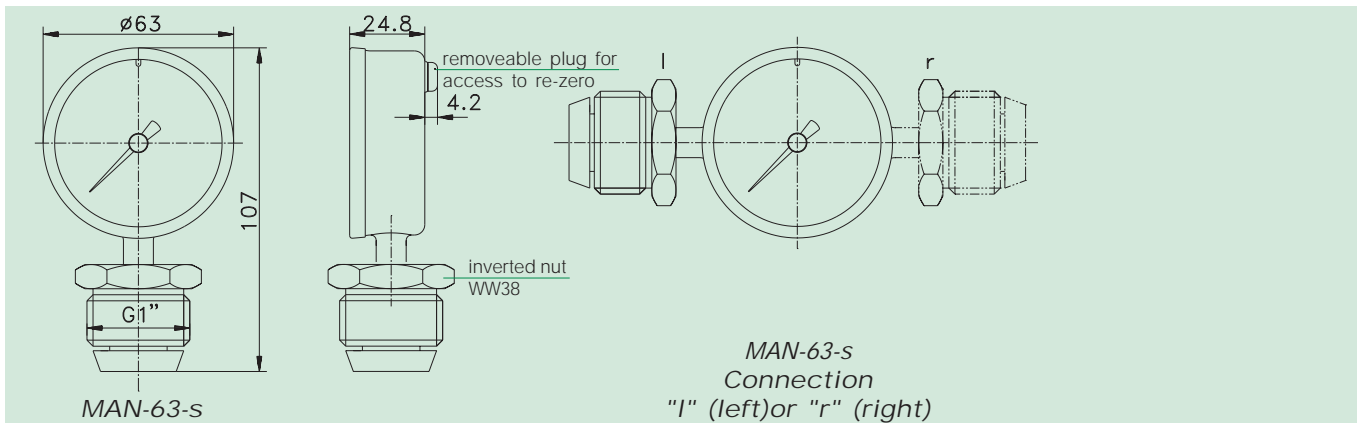

Overview of deliverable process connection (basic device and adapters must be ordered separately!)

Process connection	Build-in pipe EHG (DIN 11850 series 2)	Negele weld-in sleeve	TriClamp	Diary flange (DIN 11851)	DRD (press ring optional deliverable)	Varivent	APV-Inline	Adapter G1 1/2" to G1"
size								
DN25	-		AMC-352/1"-1,5"	AMK-352/25	-	-	-	AMG-352 suitable for existing G1 1/2" connection
DN40	EHG-40/1"	EMZ-352 suitable for installation in vessels	AMC-352/1"-1,5"	AMK-352/40	-	AMV-352	AMA-352	
DN50	EHG-50/1"		AMC-352/2"	AMK-352/50	AMK-352/50	AMV-352	AMA-352	
DN65	EHG-65/1"	EMS-352 suitable for installation in pipes	AMC-352/3"	AMK-352/65	AMK-352/50	AMV-352	AMA-352	
DN80	EHG-80/1"		AMC-352/80	AMK-352/80	AMK-352/50	AMV-352	AMA-352	
DN100	EHG-100/1"		AMC-352/4"	AMK-352/100	AMK-352/50	-	AMA-352	

Order example: TriClamp for DN100: AMC-352 / 4"