

# Level Sensor with G1/2" Thread Hygienic



## Application

- level detection of fluid and conductive media in vessels and pipes (min. conductivity 1µS/cm but depending on the transmitter)

## Application Examples

- full- / empty detection in vessels
- dry running protection of pumps
- overflow protection in dosing plants

## Hygienic Design / Process Connection

- hygienic and easy cleanable measurement point (EHEDG; 3A certificate)
- elastomer free sealing system, the connection will be without gaps and crevices (see Product Info 'Processconnection')
- CIP- / SIP-cleanable up to 140°
- food compatible materials according to FDA
- sensor completely made of stainless steel and PEEK isolation of PFA
- adapters available for all current process connections

## Features

- defined position of the cable entry
- available with or without integrated level transmitter
- different electrical connections available
- individual shortening and twisting of the rod is possible

## Options / Accessories

- high temperature version available (with neck tube 100mm)
- cable version (NVS-18x) available with different cable lengths
- integrated resistance (100k) for open circuit alarm

## Selection of the right sensor type

- Coating  
For foamy, adhesive (e.g. yoghurt) and wetting media (e.g. alkaline solutions), we suggest to use a sensor with a coated rod. Sensors with bright rod are suitable for watery, not adhesive and not wetting media.
- Temperature  
If a sensor with integrated level transmitter mnv is needed, we suggest to use the high temperature versions if the medium temperature is higher than 100°C (option .h).

Attention: Use only Negele weld-in systems, to ensure a safe function of the measurement point!

## Order Code

Model: Connection head Ø55mm; electrical connection via cable entry					
type	rod (electrode)	rod length	level transmitter mnv	high temp. version	open circuit alarm
NVS-141	stub	4mm*	.m (mit mnv-1)***	.h (neck tube 100mm)***	.d (100kOhm, only without mnv)
NVS-143	bright	200; 500; 850; 1000;			
NVS-146	coated	1500; 2000mm**			
Model: Connection head Ø18mm; electrical connection via M12-plug					
type	rod (electrode)	rod length	level transmitter mnv	high temp. version	open circuit alarm
NVS-161	stub	4mm*	.m (mit mnv-m)***	.h (neck tube 100mm)***	.d (100kOhm, only without mnv)
NVS-163	bright	200; 500; 850; 1000;			
NVS-166	coated	1500; 2000mm**			
Model: Connection head Ø18mm; electrical connection via fixed cable					
type	rod (electrode)	rod length	level transmitter mnv	high temp. version	open circuit alarm
NVS-181	stub	4mm*	.m (mit mnv-m)***	.h (neck tube 100mm)***	.d (100kOhm, only without mnv)
NVS-183	bright	200; 500; 850; 1000;			
NVS-186	coated	1500; 2000mm**			
Order example:	NVS-146 / 200.m.h			* only for NVS-141; -161; -181 ** only for NVS-143;-146;-163;-166;-183;-186 *** without: no declaration necessary.	



NVS-146



NVS-161.m



NVS-181



EHG-65/1/2"



EMZ-132

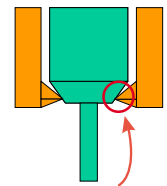

hygienic elastomerfree sealing system

## Specification Level Sensor

Process connection	hygienic	Weld-in fitting e.g. EMZ-132 or EHG-... / 1/2"
Rod length (cutable)	torque	5-10Nm (0,5-1kpm)
	NVS-141;161;181	4mm
Material	NVS-143;146;163	200; 500; 850;
	166;183;186	1000; 1500;2000mm
Pressure	Connection head	303 (1.4305)
	Rod / Electrode	316L (1.4404)
	Isolator	PEEK (acc. to FDA)
	Coating	PFA (acc. to FDA)
Temperature range	process / cleaning*	140°C
	ambient*	-10...+60°C
Electr. connection	cable entry	M16x1,5 (PG)
	plug-in	M12-plug 303 (1.4305) 3/4pol.
Protection class	cable 2,5m	
	with level transmitter	Silicone 2x0,5mm <sup>2</sup>
	without level transmitter	PVC 4x0,25mm <sup>2</sup>
		IP69K

\* If a level transmitter is integrated, please take care about the temperature specification of the level transmitter (see below).

## Level transmitter mnv-1; mnv-m

Temperature	operating	-10...+60°C
	storage	-20...+60°C
Humidity	without condensate	0...95% r.F.
Power Supply		15...36VDC
Electrode E1	voltage	1,5...2VAC/300Hz no DC signal
Sensitivity selectable	mnv-1	0,1; 1; 10; 100 kOhm
	mnv-m	0,2; 2; 20 kOhm
Output	short-circuit-proof	active 50mA
Delay	fix	0,5s
Switching logic		
min/max selectable	mnv-1	via jumpers
	mnv-m	polarisation of supply

## Dim. Drawing option neck tube



Level sensor  
NVS-141.m with  
level transmitter  
mnv-1

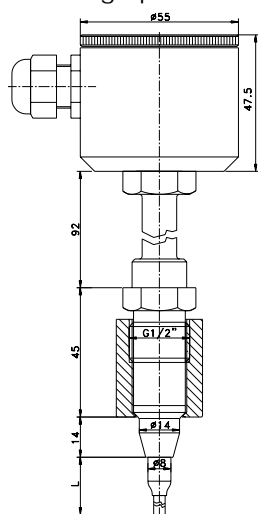

NVS-143.h

## Mounting Instructions

- Take attention of the maximum torque when you build in the sensor (5-10Nm)!
- To guarantee a safe function, take a look on a good electrical connection between process connection and pipe or vessel.  
**Do not use any kind of sealing band like e.g. Teflon tape!**
- If the stub sensor (e.g. NVS-141) is used in pipes, take care that the electrode will emerge if the pipe runs out. We propose to install the sensor in vertical pipes.
- Vessel resp. pipe wall must be of metal!
- For mounting and demounting the sensor, please use the spanner flat only! Do not use the connection head!

## Startup the Level Sensor

- If necessary cut the electrode to the length you need. Take care that the compound between rod and sensor is not stressed too much. Do not damage the coating of the rod on the sensor side!
- Strip the isolation of coated rods at the sensor tip. 5mm are most time enough.
- Screw the sensor into the fitting. Electrical connection according page 3. Take care of the coating when you mount the sensor!

## Startup the level transmitter mnv-1, mnv-m

- connect the module to power supply
- setup the switching logic (description see page 3)
- select the lowest sensitivity (0,1k) (description see page 3)
- wetting the electrode with the medium with the lowest conductivity
- if the output is switching, the setup is finished
- if the output is not switching, increase the sensitivity until the output is switching. Setup is finished.

## Calculation of the minimum conductivity of the medium

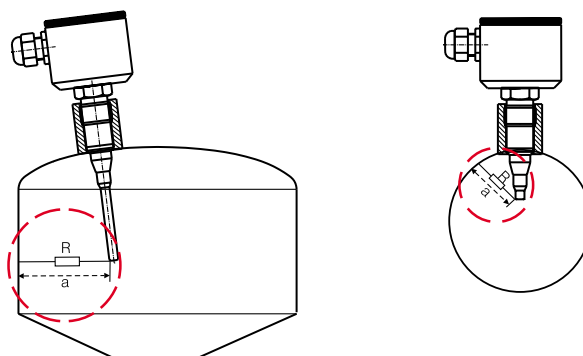

a = shortest absolute length between vessel/pipe and electrode  
 K = geometric factor for the distance a (a/cm<sup>2</sup>)  
 R = resistance of the medium  
 $R_{max}$ : NVS-14x.m = 100kOhm  
 NVS-16x.m; NVS-18x.m = 20kOhm

Example for the calculation of the minimum conductivity with NVS-141.m

Distance a = 2,5cm; factor K: 2,5/cm  
 maximum resistance  $R_{max}$ : 100kOhm  
 minimum conductivity  $con_{min}$ : 1/100kOhm = 10μS  
**specific minimum conductivity of the medium:**  
 $con_{min} (\mu S) \times K (1/cm) = 10\mu S \times 2,5/cm = 25\mu S/cm$

If the conductivity of your medium is lower than the calculated value the NVS-141.m can be used if the distance is reduced by another sensor position.

## Dimension Drawings

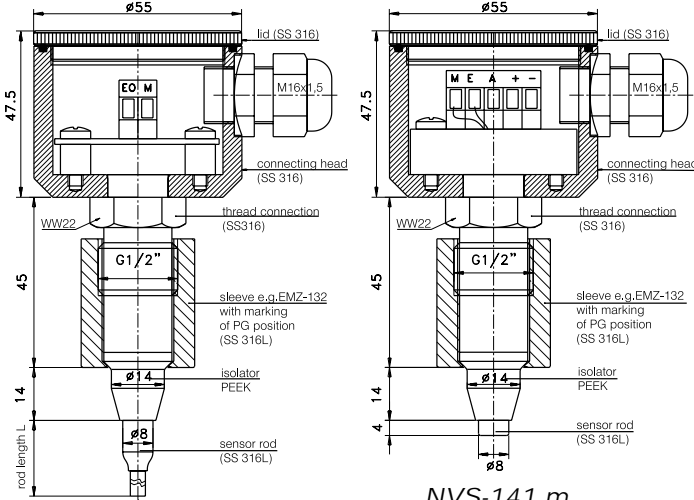

NVS-143

NVS-141.m

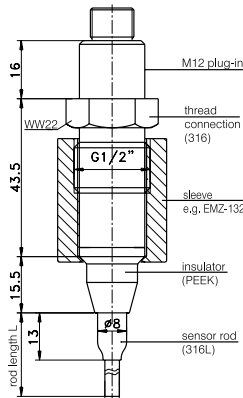
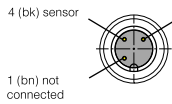

NVS-163

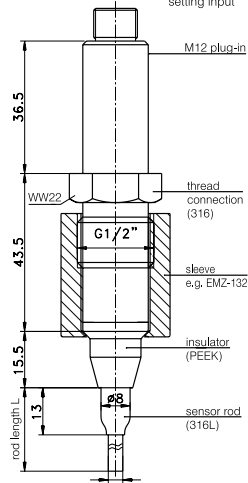
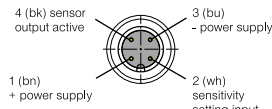

NVS-163.m

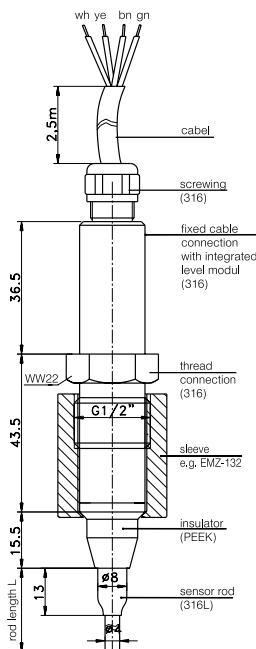

NVS-183.m

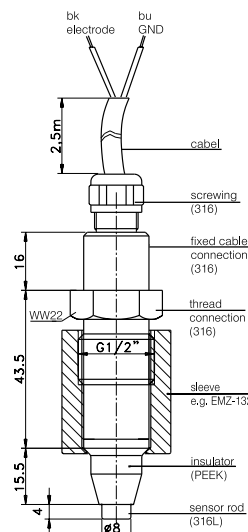

NVS-181

## Electrical Connection

NVS-141.m; NVS-143.m; NVS-146.m

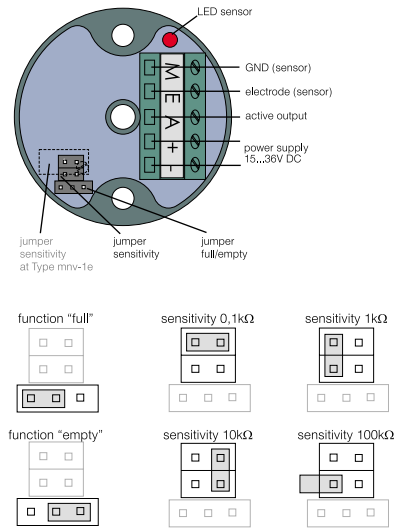

NVS-161.m; NVS163.m; NVS-166.m

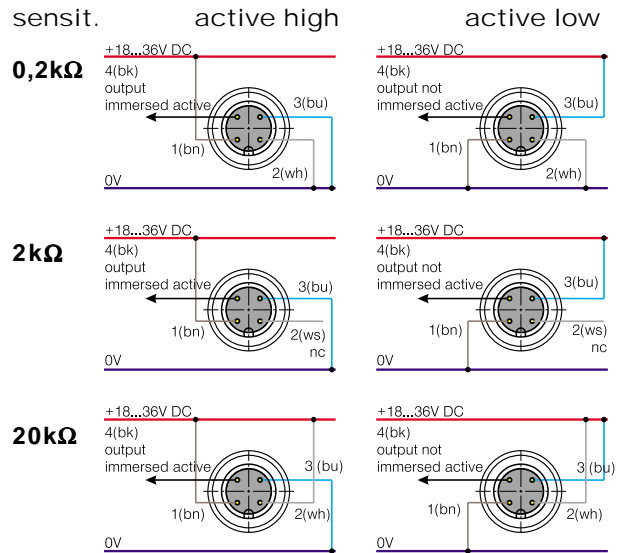

NVS-181.m; NVS-183.m; NVS-186.m

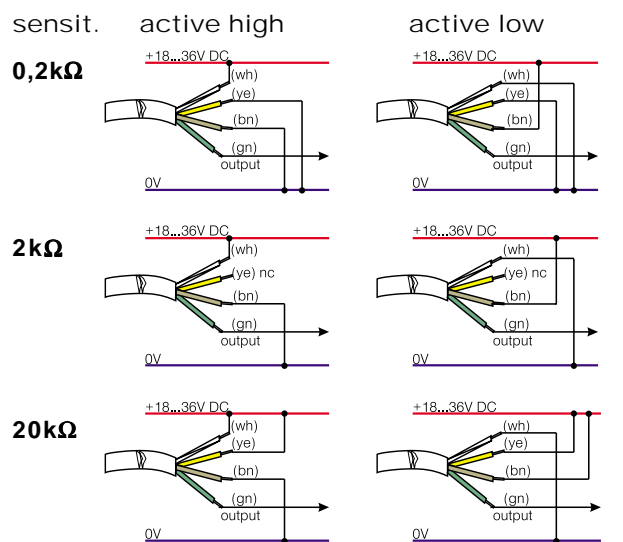

## Table Torque

Thread size	Sealing system	Torque min. [Nm]	Torque max. [Nm]
G1/2"	PEEK/SS	5	10

## Process connection G1/2" hygienic

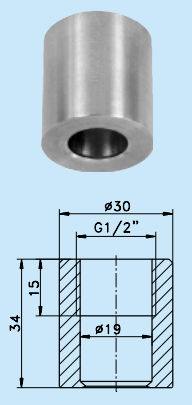
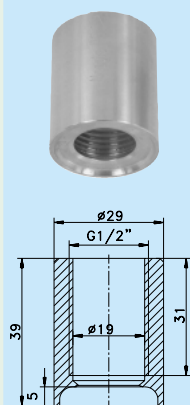
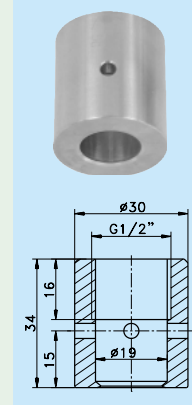
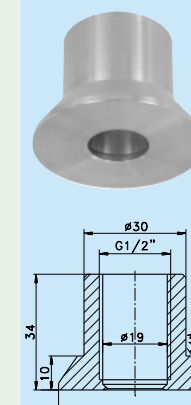
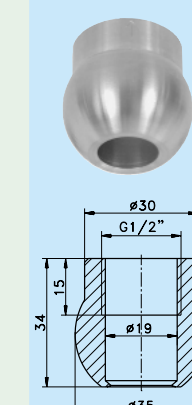
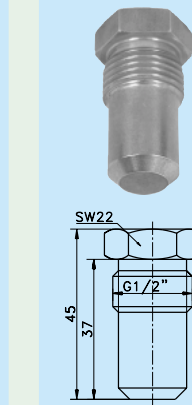



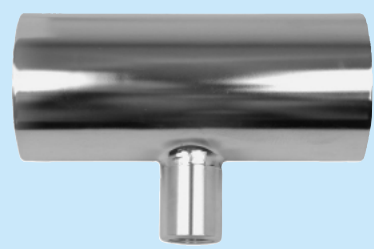

Cylindrical weld-in fitting (standard)	Cyl. fitting with weld-on ring (standard)	Cylindrical fitting with control-holes	Weld-in fitting with collar	Weld-in ball	Dummy flange BST
for vessels	for installation in pulled-out pipes	for vessels, with leakage detection	for thick-walled vessels	for sloped installation	to close existing measurement point
					
EMZ-132	EMS-132	EMZ-131	EMK-132	KEM-132	BST-130

## Dimension table EHG-... / 1/2"

Type	DN	L[mm]	A[mm]
EHG-25 / 1/2"	25	100	15
EHG-40 / 1/2"	40	120	22
EHG-50 / 1/2"	50	140	29
EHG-65 / 1/2"	65	160	38
EHG-80 / 1/2"	80	180	46

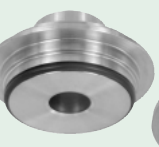

## Overview of all available process connections

Thread size	TriClamp	Dairy flange (DIN 11851)	DRD (press ring optional available)	Varivent-Inline	APV-Inline	BioControl	Adapter G1/2" / G1"
G1/2" adapter							
Pipe size	AMC-132/1"-1,5"	AMK-132/25	AMK-132/50 (only one size)	AMV-132/25	-	-	AMG-1
DN25	AMC-132/1"-1,5"	AMK-132/40		AMV-132/40	AMA-132	AMB-50/1/2"	
DN40	AMC-132/2"	AMK-132/50		AMV-132/40	AMA-132	and	
DN50	AMC-132/2"	AMK-132/65		AMV-132/40	AMA-132	AMB-65/1/2"	
DN65	AMC-132/3"	AMK-132/80		AMV-132/40	AMA-132	from DN40	
DN80	AMC-132/3"	AMK-132/80	AMV-132/40	AMA-132	up to DN100		
DN100	AMC-132/4"	AMK-132/100	AMV-132/40	AMA-132			