



WEIGHING INDICATOR

SERIE IPE 50

User manual 2/2
Refer to the user manual 1/2
Dedicated to specific function
and output RS232 / 485 / printer

(valid from version 07.00)



INDEX

This user manual is a user manual complementary to the user manual series IPE50
1/2

16	Basic function	P3
17	Selectable operating modes	P5
18	port communication RS232 and 485	P17
	18.5 communication protocol	P24
19	Printer output	P26

16 BASIC FUNCTION

Complement of the user manual 1/2

16.1 AUTO POWER OFF FUNCTION

It is possible to automatically turn off the indicator (from 1 to 255 minutes), or disable it; the auto power off takes place when, with unloaded scale, or a key has not been pressed for the time set: the display shows the “- oFF –” blinking message and the indicator turns off.

For the setting, follow the procedures below:

- Select menu F.Mode.
- Press ENTER to enter the menu.
- Press ->0<- many times (to scroll ahead through the parameters) or ->T<- (to scroll backwards) until one finds the “AutoFF” parameter.
- Press ENTER to enter the parameter.
- With the ->0<- or ->T<- keys select the possible options: “diSAb” (auto switch-off disabled), “EnAb” (auto switch-off enabled).
- Confirm with ENTER if “EnAb” has been selected, one will be asked to enter the number of minutes after which the indicator should turn off: enter a number between 1 and 255 (using the MODE key to select the digit to be modified and ZERO/TARE to decrease/increase it) and confirm with ENTER
- Press many times the C key until the display shows “SAVE?”.

Press ENTER to confirm the changes made or another key for not saving.

16.2 MULTI RANGE FUNCTIONING (for legal for trade approved instruments)

The multi range functioning allows to subdivide the scale capacity in two ranges, each which is up to 3000 divisions, improving in this way the first range division in the dual range and the first two ranges in the triple range.

For example, with a 10 kg cell platform it is possible to approve the weighing system with:

- A single range: 6 kg capacity and 2 g division (3000 div.).
- Dual range: 6 / 3 kg capacity and 2/1 g division (3000 + 3000 div.).

NOTE: The selection of the range number with multirange functioning is made during the indicator's calibration

16.3 DATE/TIME ADJUSTMENT (OPTIONAL)

The indicator can be fitted with the date/time option; in this case, the “CLoCK” message is shown when instrument is turned on.

To set the date/time follow the procedure below:

- Select menu F.Mode.
- Press ENTER to enter the menu.
- Press ->0<- many times (to scroll forwards through the parameters) or ->T<- (to scroll backwards) to find the “CLoCK” parameter.
- Confirm with ENTER/PRINT: in this order one will be asked to enter the day, month, year, hour, and minutes. The entry of each parameter must be confirmed with ENTER
- Press the C key many times until the message “SAVE?” appears on the display.
- Press ENTER to confirm the changes made or another key to not save.
- It is possible to programme the date and time during the weighing, pressing in sequence the F and 8 keys.
- The “CLoCK” parameter is not displayed if there is no date/time option.

16.4 "SCREEN SAVER" FUNCTION (OPTIONAL)

If the indicator is fitted with the date/time function, it is possible to enable the "Screen Saver": after a programmable time (from 1 to 255 minutes) with the scale unloaded, the time is shown on the display, in the "HH-MM-SS" format. As soon as a weight variation is detected, or a key is pressed, the indicator returns to viewing the current weight.

To set the function:

- Select menu F.Mode.
- Press ENTER to enter the menu.
- Press ->0<- many times (to scroll forwards through the parameters) or ->T<- (to scroll backwards) to find the "SCr.SAV" parameter.
- Press ENTER to enter the parameter.
- With the ->0<- or ->T<- key select the possible options: "no" (disabled), "YES" (enabled).
- Confirm with ENTER if one has selected "YES", one is asked to enter the number of minutes after which the indicator should show the time: enter a number between 1 and 255 (using the MODE key to select the digit to be modified and the ZERO/TARE keys to decrease/increase it) and confirm with ENTER
- Press the C key many times until the display shows the message "SAVE?".
- Press ENTER to confirm the changes made or another key to not save.

NOTE: the "SCr.SAV" parameter is not shown if there is no date/time option.

16.5 PRINTING

If a printer is connected, it is possible to print the programmed weight data, for example:

- GROSS weight
- TARE weight
- NET weight
- ticket number
- date and time (optional)
- a CODE 39 bar code (both with the LP542PLUS labeller as well as the TP200 thermal printer).

Besides the generic printing described above, each single functioning mode will have some specific printouts, which are described in the operating mode.

Executing printouts with NON approved scales.

In order to print with non approved scales the following conditions must exist:

- the weight must be stable;
- the gross weight must be \geq of a division;

To configure the printouts, go to the "PROGRAMMING THE PRINTOUTS"

16.6 REENABLING THE PRINTOUTS AND THE INDICATOR FUNCTIONS

While using the indicator, it is possible to incur into the "no.0.unS" error shown on the display along with an acoustic signal; this means that the printing or the function which one wants to carry out must be reenabled (in order to avoid unwanted executions).

It is possible to set the reenabling in different ways: "passage by zero of the net weight", "weigh instability" or "always". Follow the procedure below:

- Select menu F.Mode.
- Press ENTER to enter the menu.
- Press ->0<- many times (to scroll forwards through the parameters) or ->T<- (to scroll backwards) until one finds the "rEAct" parameter.
- Press ENTER to enter the parameter.
- With the ->0<- or ->T<- keys select the possible options: "ZEro" (passage by zero of the net weight), "inSt" (instability), ALWAYs.
- Confirm with ENTER
- Press the C key many times until the message "SAVE?" is shown on the display.
- Press ENTER to confirm the changes made or another key to not save.

17 SELECTABLE OPERATING MODES

In addition to the STANDARD weighing mode with TARE deduction and transmission of data, the indicator can carry out one of the following functions:

kg/lb CONVERSION, NET/GROSS SWITCH, SET POINT ON THE GROSS WEIGHT, SET POINT ON THE NET WEIGHT, IN/OUT, ALIBI, DISPLAY WITH SENSITIVITY X 10, HOLD THE DISPLAY, PEAK, HORIZONTAL TOTALIZER, VERTICAL TOTALIZER, PIECE COUNTING.

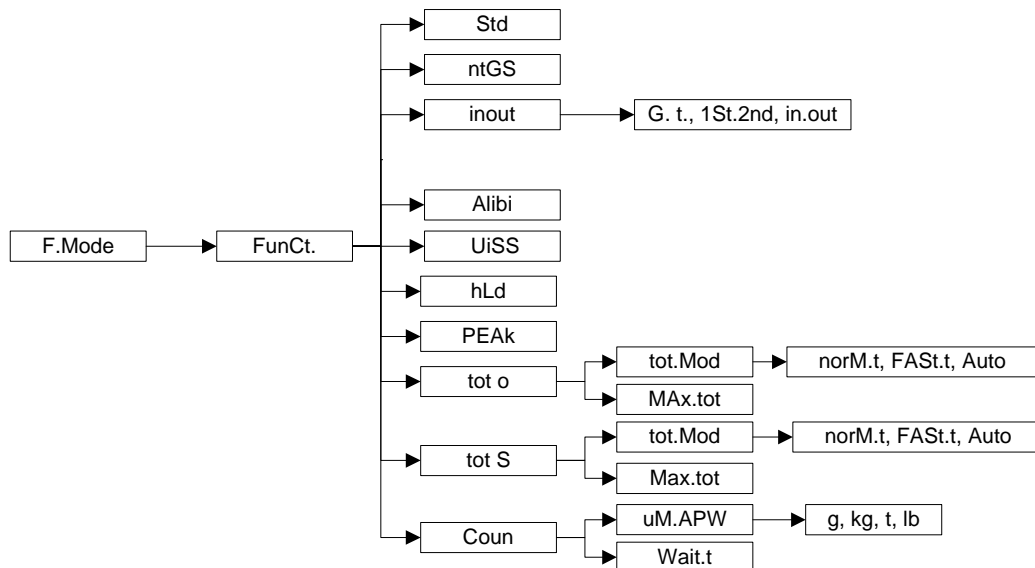

To set the operating mode, carry out the following procedures:

- Turn on the unit, L. 1.06 and after 07.xx are displayed, press the ->0<- key when 07.xx is displayed, after 09.01, DGT9 and the version of the software are displayed, press ->T<- key during the countdown (the display shows the “F.ModE” menu).
- Press ENTER to enter the menu (the display shows the “FunCt” menu).
- Press ENTER to enter the parameter.
- With the ->0<- or ->T<- keys select the possible options:

<i>Std</i>	kg / lb conversion
<i>ntGS</i>	net weight / gross weight conversion
<i>inout</i>	Input / output weighing
<i>ALibi</i>	memory Alibi / DSD (option)
<i>UiSS</i>	Sensitivity (x10)
<i>hLd</i>	Hold
<i>PEAK</i>	Peak detector
<i>tot o</i>	Horizontal totalizer
<i>tot S</i>	Vertical totalizer
<i>Coun</i>	Counting
- Confirm with ENTER if one has selected the inout, tot or, tot S or Coun mode, one will be asked to select another operating parameter; refer to the specific functioning mode section for the relative description.
- Once the functioning mode is selected, one is asked to enable the standard printouts: the “dEF.Pr?” message appears on the display: press ENTER to enable the printouts and C to exit without making any modifications.
- The instrument automatically goes to the following step.

- Press many times the C key until the display shows the message "SAVE?".
- Press ENTER to confirm the changes made or another key to not save.
-

17.1 HOLD: FREEZING THE WEIGHT ON THE DISPLAY (HLd)

By pressing MODE, the value of the weight is held on the display, and the display shows HoLd alternately with the weight held value (every 5 sec). To release the weight value on the display, press MODE key again.

17.2 PEAK : WEIGHT MAX DETECTION (PEaK)

It is possible to use the instrument to store the maximum weight value measured during the weigh (PEAK), useful to measure, for example, the breaking load of the materials.

By pressing MODE the peak mode is enabled, and the display shows "PEAK" alternating with the held weight value (every 5 sec).

To stop the test and return to standard operation press MODE key again, (for an instant "PEAKoF" is displayed).

The detected weight value will be:

- The maximum before a rapid decrease of the weight (measurement of the ultimate load).
- The maximum and persistent weight detected on the scale.

SETTING SAMPLING TIME

It is possible to set the minimum time period of the peak impulse beyond which the measuring is accepted. This time is set by keeping "ENTER/PRINT" pressed for a few seconds when the indicator is not in the peak mode: the message tPI C then -tP- appears on the display followed by a number which corresponds to the minimum time length of the impulse expressed in hundredths of seconds.

By pressing "->0<- or ->T<-" the following settable values are proposed: 1, 2, 3, 4, 5, 10, 20, 50, 100, and 127; press "ENTER/PRINT" to confirm the desired value (value in 1/100 of second), the indicator will return to weighing.

The default value is 1.

(If the setpoints are operational, the fact of pressing on the key ENTER/PRINT also makes it possible to modify the value of the setpoints, the choice is done by the keys ->0<- or ->T<- when appears the PiC.tiM message. (see paragraph of the setpoints). Attention with the value of the filter.

17.3 ALIBI MEMORY (ALibi) - option

The alibi memory allows to record the displayed weight in the memory for data processing and/or integration. The recorded values may then be recalled from the PC serial line or directly on the indicator's display for a following check.

The storage of a weigh takes place either following the reception of the serial command or following the pressure of the ENTER key: the indicator transmits on the PC serial line the gross and tare weights and an ID which clearly identifies the weigh.

The storage of a weigh in the alibi memory is possible only if the weight is stable; (it can not be in underload or in overload) and the gross must be equal or greater than zero. In case these conditions are not respected:

_in the response to the PID serial command there will be "NO" instead of the ID;

_there is no transmission in the case that the ENTER key is pressed.

When one presses the ENTER key, the weight and the ID is transmitted and the display shows the "tr.id" message for about 2 seconds.

The ID has the following format:

<Rewriting number> — <Weigh number>

Rewriting number: number of 5 digits which may go from 00000 to 00255; it indicates the number of complete rewritings of the alibi memory.

Weigh number: number of 6 digits which may go from 00000 to 131072; it indicates the weigh number in the current rewriting of the alibi memory

With each storage the weigh number is increased of 000001; when this reaches the 131072 value, it restarts from 000000 and the rewriting number increases of 00001.

Example:

If the stored weigh is the following:

"PIDST,1, 1.000kg, 1.000kg,00126-131072"

and the following will be:

"PIDST,1, 1.000kg, 1.000kg,00127-000000"

The storage of a weigh is possible only if the weight is stable, valid (in other words not in underload nor in overload) and if the gross weight is equal or greater than zero. If these conditions are not respected:

- in the response to the PID serial command one has "NO" in the place of the ID.
- there is no transmission if ENTER has been pressed.

When the weight is transmitted with the ID following the pressing of the ENTER key, the display shows for about 2 seconds the message " tr.id ", and the transmitted string is the following:

<ESC>[II]PIDSS,B,LLLLLLLLLLLLUU,YYTTTTTTTTUU,(ID | NO)<STX>.

See the following section "Serial commands" for the string description.

NOTES:

- With approved instrument, the storage of the weigh and the following transmission of the ID to PC by pressing a key is possible only if the printout is active (or passage from 0 or weight instability and minimum weight of 20 divisions).
- With approved or not approved instrument, the storage of the weigh through the PID serial command is always possible for all the weighs from 0 to full range value.

READING OF THE WEIGHS CARRIED OUT

In order to read the information relative to the weighs carried out:

- Press the **MODE** key.
- The message "rew.id" appears; now one should enter the rewriting number (from 00000 to 00255) and press ENTER
- The message " id " appears; now one should enter the weigh number (from 000000 to 131072) and press ENTER
- Now it is possible to view on the display the weigh information in sequence, and scroll through it with the ->0<- key (ahead) or the ->T<- key (backwards):
 - "ch. x", in which x is the scale number (always 1).
 - " um yy" in which yy is the unit of measure (kg, g, t o lb).
 - gross weight (for about a second the message "GroSS" appears and then the gross weight value).
 - Tare weight (for about a second the message "tArE" appears or "tArEpt" if it is a manual tare; then the tare value appears).
- Press C to return to weighing.

NOTES:

- The alibi memory can store up to 131072 weighs; then the rewriting takes place from the beginning.

- If the alibi memory is empty, when the MODE key is pressed the message "EMPTY" appears for about a second, an error acoustic signal is enabled and one returns to weighing.
- If the entered ID is not valid, in other words, if there is no stored weigh relative to the entered ID, the message "no id" appears and an error acoustic signal is enabled and one returns to weighing.

INITIALISATION OF THE ALIBI MEMORY

It is possible to cancel all the weighs made, initialising the alibi memory; this operation can be made directly on the indicator (see the parameter "SETUP" >> "ini.AL" of the set-up environment, or through the serial command (see "SERIAL COMMANDS" below).

NOTES:

- It is not possible to just cancel a single weigh.
- The initialisation is possible only with a non approved instrument.

SERIAL COMMANDS

WEIGH STORAGE

Command

[II]PID<CRLF> or <ESC>[II]PID<STX>

in which: [II]: 485 address
 <ESC>: 27 ascii decimal character
 <STX>: 2 ascii decimal character

Instrument response to the [II]PID<CRLF> command:

[II]PIDSS,B,LLLLLLLLLLUU,YYTTTTTTTTTUU,(ID | NO) <CRLF>

Instrument response to the <ESC>[II]PID<STX> command:

<ESC>[II]PIDSS,B,LLLLLLLLLLUU,YYTTTTTTTTTUU,(ID | NO)<STX>

In which:[II] 485 address (only when transmitting in 485 mode)
 SS OL" (weight in overload) or "UL" (weight in underload) or "ST" (stable weight) or "US" (unstable weight) or "TL" (TILT input closed).
 B scale number (always 1)
 LLLLLLLLLL: gross weight on 10 digits
 UU: unit of measure
 YY: 2 spaces in the case of null tare or semiautomatic tare, "PT" in case of manual tare
 TTTTTTTTTT: tare on 10 digits
 ID XXXX-YYYYYY in which: XXXXX is the rewriting number (5 digits, from 00000 to 00255) and YYYYYY is the weigh number (6 digits, from 000000 to 131072).

In the case in which the gross weight is negative or unstable, the weight is transmitted but not the ID; "NO" is in its place. In these cases there is no storage in the alibi memory.

Command to receive the date and time with the weight

[II]PIDD<CRLF> or <ESC>[II]PIDD<STX>

Instrument response to the [II]PIDD<CRLF> command:

[II]PIDSS,B,LLLLLLLLLLUU,YYTTTTTTTTTUU, JJ/MM/AA HH:MM:SS (ID | NO) <CRLF>

date : JJ/MM/AA -> ex : 24/04/07 time : HH:MM:SS -> ex : 11:23:46

WEIGH READING

Command:

[II]ALRDXXXXX-YYYYYY <CR o CRLF>

In which: [II] 485 address (only when transmitting in 485 mode)
XXXXXX rewriting number (from 00000 to 00255)
YYYYYY weigh number (from 000000 to 131072)

Instrument response:

[II]B,LLLLLLLLLLUU,YYTTTTTTTTTUU<CR o CRLF>

In which: [II] 485 address (only when transmitting in 485 mode)
B scale number (always 1)
LLLLLLLLLL gross weight on 10 digits
UU unit of measure
YY spaces in the case of null or semiautomatic tare, PT in the case of manual tare
TTTTTTTTTT tare weight on 10 digits

ALIBI MEMORY RESET (only with non approved instrument)

Command:

[II]ALDL <CR o CRLF>

In which [II] 485 address (only when transmitting in the 485 mode)

Instrument response:

[II]ALDLOK <CR o CRLF> if the cancellation has been effective

[II]ALDLNO <CR o CRLF> if the cancellation has not worked

The commands are ignored if the unit is not in the alibi memory functioning mode.

Nota: it could take several minutes to reset the data in the memory

17.4 INPUT/OUTPUT (in out)

Simple display functioning mode with in / out weighing function: the indicator acquires two weight values through the confirmation of the operator and calculates the difference, automatically printing the data (if the presence of a printer has been configured).

Once the in/out mode has been selected, the message "tyPE" is shown and one is asked to select with ENTER the printing mode of the acquired data:

- **G.t. gross/tare:**

GROSS Greater weight with unit of measure
TARE Lesser weight with unit of measure.
NET Difference between GROSS and TARE with unit of measure

- **1st.2nd first weigh/second weigh:**

WEIGH 2 Second weight with unit of measure.
NET Difference without sign between WEIGH 1 and WEIGH 2 with unit of measure.

- **in.out input/output:**

INPUT First weight with unit of measure.
OUTPUT Second weight with unit of measure.
NET Zero weight with unit of measure >> if WEIGH 1 = WEIGH 2

INPUT NET >> if WEIGH 1 > WEIGH 2
Difference without sign between INPUT and OUTPUT with unit of measure.

OUTPUT NET >> if WEIGH 1 < WEIGH 2
Difference without sign between INPUT and OUTPUT with unit of measure.

PROCEDURE:

- By pressing MODE key the unit acquires the first weight, on the display is shown " - - 1 - - -";
- By pressing again MODE key, the unit acquires the second weight, and on the display is shown " - - 2 - - -".
- **NOTE:** The acquisition of the second weight is made only if the setting of the rEACt parameter in the set-up environment has been respected (passage by zero of the weight instability, or always); see section 9.11 "REENABLING OF THE PRINTOUTS AND THE INDICATOR FUNCTIONS".
- When the second weight is acquired, the data printout is commanded:

It is possible to interrupt the weighing cycle by pressing the C after the acquisition of the first weight: On the display the message " CLEAR " is shown accompanied by a prolonged beep. Press ENTER to confirm the cancelling of the first acquired weight or another key to not confirm.

NOTES:

The first weight is acquired if:

- With a NON APPROVED scale one has a STABLE weight and GREATER than 0.
- With an APPROVED scale one has a STABLE weight and GREATER than 20 divisions.

The second weight is acquired if:

- With a NON APPROVED scale one has a STABLE weight and GREATER than 0.
- With an APPROVED scale one has a STABLE weight and GREATER than 20 divisions.
- if the setting of the rEACt parameter in the set-up environment has been respected (passage by zero of the weight, instability, or always); see section "REENABLING OF THE PRINTOUTS AND THE INDICATOR FUNCTIONS".
- the tare operations are DISABLED.

17.5 HORIZONTAL TOTALIZER (Sum of lots -> tot 0)

If the unit is switched OFF, the totalizer will be resetted

Tot.Mod : TYPE OF TOTALISATION (NORMAL, FAST, AUTOMATIC)

Once the totalizer operating mode is selected, both horizontal and vertical, one is asked to set the type of totalization: normal (t.norM), fast (t.FASt) or automatic (Auto); with ->0<- or ->T<- one changes the parameter; with ENTER one confirms.

- **t.norM** : In the normal totalisation, for each accumulation operation there is the display of the weigh number and the net weight total, before the printing of the data.
- **t.FASt** : In the fast one, just the display of the "-tot-" message appears on the display, before the printing of the data.
- **Auto** : In the automatic one, there is the automatic acquisition of the stable weight; therefore the display of the "-tot-" message on the display and then the printing of the data.

MAx.tot: NUMBER OF CONSECUTIVE TOTALISATIONS AFTER WHICH THE TOTAL IS AUTOMATICALLY PRINTED AND RESET

After having carried out the set weighs, the accumulated general total is printed and reset; set a value between 00 and 63.

NOTE: the value 00 disables the function

TOTALISATION OPERATIONS

In order to carry out the totalisation it is necessary to press the MODE key (if the automatic totalisation has not been set): the weight is accumulated in two total levels (a partial total and a general total).

To totalize, the net weight must be at least one division with non approved instrument and of at least 20 divisions with approved instrument.

To avoid undesired accumulations, the "MODE" key is active just once; it reactivates depending on the

setting of the " rEACT " parameter in the SET-UP environment, in other words, either after passing by the net zero of the scale, by instability or always (see section "REENABLING OF THE PRINTOUTS AND THE INDICATOR FUNCTIONS").

If the presence of a printer has been configured, the "MODE" key or automatically causes also the printing of the weight values.

After a totalisation, press the MODE key again:

- with the normal totalizer, one can temporarily view on the display the number of weighs carried out and the PARTIAL NET TOTAL accumulated until that moment (Subtotal): if the accumulated digit is more than 6 digits the visualisation takes place in two stages.
- with the fast totalizer the " no.0.UnS " error message is displayed.

NOTE:

- If the gross or net weight is equal to zero, with the normal totalizer the indicator displays the accumulated total, while with the fast totalisation the "GroS.Er or nEt.Err" error message is displayed.

TOTALISATION WITH PRINTING

If the presence of a printer has been configured, upon each pressing of MODE, one prints the data programmed in step SETuP >> SEriAL >> CoM.Prn >> Pr.ConF of the set-up environment (TECH.MAN.REF.), for example:

- Weigh number
- GROSS weight
- TARE weight
- NET weight

PRINTING AND ZEROING OF THE TOTALS

The instrument has two different total levels, a partial total and a general total, which increase upon each totalisation; these may be printed and zeroed independently from each other.

To print and zero the PARTIAL TOTAL one should press for a short time the ENTER key; depending on the type of totalisation, various messages will be displayed:

- With **normal totalisation** the number of weighs and the accumulated total will be displayed.
- With **fast or automatic totalisation** the message "totAL" will be displayed.

The number of weighs made and the NET WEIGHT TOTAL is printed.

To print and zero the GENERAL TOTAL one should press for a few seconds the ENTER key; depending on the type of totalisation; various messages will be displayed:

- With **normal totalisation** the number of weighs and the accumulated total will be displayed.
- With **fast or automatic totalisation** the message "G.totAL" will be displayed.

The number of weighs made and the NET WEIGHT TOTAL is printed.

NOTE:

All the values accumulated are automatically zeroed each time the instrument is turned off.

17.6 VERTICAL TOTALIZER (Sum by recipe -> tot S)

Like the horizontal totaliser but with each pressing of MODE (or automatically depend of parameter rEACT) the indicated weight is totalised and automatically tared; in this way it is possible for example to fill a container with various products and to know the total weight of the container (on the display or/and on a printer) and the total weight of all the containers weighted (on the display or/and on a printer) .

17.7 PIECE COUNTING (COUn)

In this functioning mode it is possible to carry out the reference operations in order to use the scale for counting pieces.

When the functioning mode is selected (F Mode -> FunCt -> Coun) , one is asked to set some parameters:

- "uM.APW" : unit of measure of the average unit weight (APW).
 - Press ENTER to enter the step.
 - With the ->0<- or ->T<- keys select the unit of measure (*g/kg/t/Lb*).
 - Confirm with ENTER
 - "WAI.t" : sampling interval.
 Setting of the sampling time (in seconds, with a decimal); greater is the time set and more precise will the calculated APW be.
 - Press ENTER to enter the step.
 - Set the desired time.
 - Confirm with ENTER
 - Press many times the C key until the display shows the message "SAVE?".
- Press ENTER to confirm the changes made or another key to not save.

COUNTING PROCEDURE

The operations to be carried out are the following:

- 1) Place the empty container on the scale and press ->T<- to tare it.
- 2) Check that the zero is on the display and press the MODE button: the counting function activates
- 3) The display suggests a REFERENCE QUANTITY. The possible options are: 5, 10, 20, 30, 40, 50, 60, 75, 100, 200.
- 4) Press "->0<- or ->T<-" the number of times needed to reach the desired sample size.
- 5) Put the quantity of pieces chosen for the SAMPLE on the scale and press ENTER to confirm or C to cancel the operation and return to weighing.
- 6) Press ENTER the display will indicate SAMPL and the indicator will calculate the Average Piece Weight (APW). After a few instants (time set in parameter Wait.t) the display will indicate the quantity selected put on the platform.
- 7) Add the rest of the items to count in the container and whose value will appear on the display.
- 8) Unload the scale, the APW will remain stored in memory for the next counting of similar pieces, without having to repeat the REFERENCE operation.
- 9) By pressing the MODE key one switches from the display of the number of pieces piece (LED "SPE" on) to the display of the net weight piece (LED "SPE" off) and vice versa.
- 10) To carry out a new reference operation, press the MODE key and repeat the operations as describe in point 3).

NOTE: If the number of calculated pieces is greater than 999999, the display shows just the first 6 digits on the right.

PIECE COUNTING IN EXTRACTION

- 1) Load a FULL container on the scale and press "->T<-" to tare it.
- 2) Press "MODE": The display suggests various REFERENCE QUANTITIES:
5,10,20,30,40,50,60,75,100,200
- 3) Press "->0<- or ->T<- " various times until the chosen quantity is displayed.
- 4) From the container take off the same number of pieces and press "ENTER/PRINT" to confirm. The display shows "SAMPL" while the indicator calculates the Average Piece Weight. The display shows in negative the quantity extracted.
- 5) Continue the counting in extraction.

"Er.Mot" ERROR DUE TO WEIGHT INSTABILITY DURING THE SAMPLING

It may happen that during the sampling phase the weight is unstable and therefore it is not possible to correctly calculate the APW. The "Er.Mot" is shown remaining for about three seconds. One should therefore repeat the sampling operation.

MINIMUM WEIGHT OF THE SAMPLE

It is advisable to use a reference quantity equal or greater than 0,1% of the scale capacity.

In any case, the weight of the reference quantity should not create an APW lower than the two internal points of the converter (intrinsic limit of the instrument); if this condition takes place, during the sampling, the display will indicate for an instant: "Error " and the quantity put on the plate will not be accepted. One should therefore use a higher reference quantity.

PRINTING UNDER COUNTING MODE

If the presence of a printer has been configured, each time ENTER is pressed, while either weight or pieces are displayed, one prints the data programmed in the SETuP >> SEriAL >> CoM.Prn >> Pr.ConF of the set-up environment; for example:

- GROSS weight
- TARE weight
- NET weight
- Quantity of PIECES (PCS) on the scale in that moment.
- calculated APW, expressed in the set unit of measure, with three decimal digits

Nota:

Setpoint in counting mode

Select in Setup : outPut for the relays : 3 PCS and these others parameters

To change the setpoint value:

Press the key ENTER at least 3 seconds, the display shows : inP.PMu, press the key : ->T<- to obtain inP.StP, press the key ENTER, the display shows : S.1 on and press ENTER to see the value and to change it if necessary with keys MODE,->0<- , ->T<- and ENTER (at this end use key C to return in counting mode).

Display and modification of average piece weight (APW)

It is possible to see and modify this value.

Press ENTER at least 3 seconds, the display shows : inP.Pmu, press ENTER again, and the bAPW is shown.

You could modify it, if necessary with keys MODE,->0<- and ->T<-.

Attention : the value can't be displayed completely in first place, to see the whole value, use the key MODE.

Block diagram serial output RS232 and 485

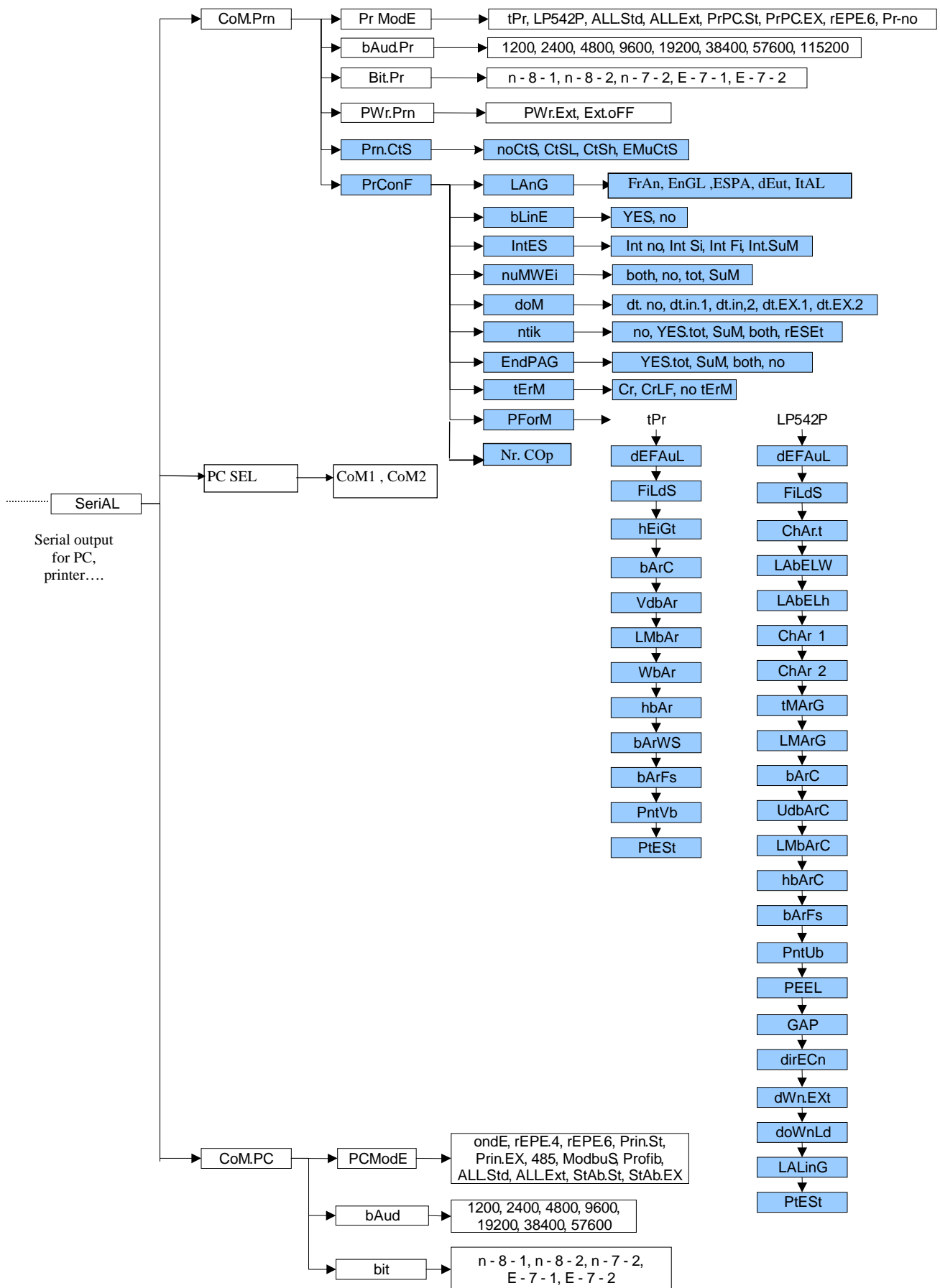

18 SERIAL RS232 AND 485 OUTPUT

The instrument has two serial outputs (1 unidirectional and 1 bidirectional), which have the output in ASCII code compatible with the majority of printers, remote displays, PCs and other devices.

It is bi-directional (halfduplex) and uses an RS232 or RS485 for transmitting data. It is mainly used to connect computers, PLCs, additional remote displays. The transmission speed may be selected in the SET UP among these: 1200, 2400, 4800, 9600, 19200, 38400, 57600, 115200 Baud (bit/sec.).

The choice of RS232 or 485, is made by the parameter SEL PC, this other port will be unidirectional.

The transmission of the data via the port serial can be configured various ways, according to the adjustment of the parameter "PCMode" in the environment CONFIGURATION: on request, continues, stabilized.

18.1 SERIAL PORT RS232 and 485 (unidirectional) (printer, repeater or PLC)

Please find below the various selectable serial weight transmission modes of the PC serial port through the corresponding "PCModE" step of the SET-UP environment.

- **TRANSMISSION TO PRINTER** ("tPr" (for TP200) and "LP542" parameter): requests the use of the print key on the indicator (prints upon request of the operator). The print command is inhibited if the weight is in motion and in all other circumstances in which the data is not valid (see "EXECUTION OF THE PRINTOUTS" section).
- **CONTINUOUS TRANSMISSION** ("ALL.Std" and "ALL.Ext" parameter): see the "ALL.Std" and "ALL.Ext" modes of the PC port.
- **TRANSMISSION OF THE PC STRING UPON PRESSURE OF THE PRINT KEY** ("PrPC.St" and "PrPC.EX" parameter): see the "Prin.St" or "Prin.EX" mode of the PC port
- **TRANSMISSION TO 6-DIGIT REMOTE DISPLAY** ("rEPE.6" (for IPE50) parameter): see the "rEPE.6" mode of the PC port.

THE CONNECTION AND THE SOFTWARE CONFIGURATION OF THE SERIAL OUTPUTS MUST BE CARRIED OUT BY TECHNICAL PERSONNEL WHO KNOW THE PROCEDURES ON THE BASIS OF THE NEEDS OF THE USER.

18.2 SERIAL PORT RS232 and 485 (bidirectional) (PLC, Master for network)

Please find below the various selectable serial weight transmission modes of the PC serial port through the corresponding "PCModE" step of the SET-UP environment.

- **TRANSMISSION REQUESTED FROM AN EXTERNAL DEVICE** "ondE" parameter
In this case the indicator waits for a command before transmitting (see the section "SERIAL COMMANDS FORMAT").
With Baud rate at 9600, through the READ command, it is possible to make up to 10-11 requests per second, while with Baud rate at 57600 one can arrive at 16.
The transmission works with weight <, =, > 0 with approved or unapproved instrument.
NOTE: This protocol is active also in the other functioning modes, only on the PC serial output.
- **4 – 6 DIGIT REMOTE DISPLAY TRANSMISSION** "rEPE.4" and "rEPE.6" (for IPE50) parameter
The weight displaying takes place both in the indicator as well as in a weight repeater of 4 or 6 digits, (normally the capacity will be properly set up for a correct displaying).
N.B. When either transmission mode is selected, the relative serial output is automatically set to 4800, N – 8 – 1.

- **TRANSMISSION WHEN THE PRINT KEY IS PRESSED** “Prin.Std”, “PrinEX” parameter
 The instrument communicates the weight data through the serial port when the ENTER key is pressed (except for in the TOTALIZER mode where one should press the MODE key).
 For non approved instruments:
 The transmission takes place if the weight is stable and the net weight is > 0.
 Reenabling the transmission depends on how the “rEAct” step has been set in the SET-UP environment (passing by zero of the NET weight, weight instability or always).
 For approved instruments:
 The transmission takes place if the weight is stable and the net weight is > 20 divisions.
 Reenabling the transmission depends on how the “rEAct” step has been set in the SET-UP environment (passing by zero of the NET weight, weight instability or always).
 The data is transmitted using the standard string (Prin.Std) or the extended string (PrinEX); see the “TRANSMISSION PROTOCOL” section for the description of the two strings.

- **TRANSMISSION IN RS 485 SERIAL MODE** “485” parameter
 The protocol is the same as the transmission upon request (ondE parameter), except that the instrument responds only if its machine code is the one requested (before the request the machine code must be put, I.E. 00READ<CRLF>).
 If a broadcast address command (99) is received no answer is given. If the command is correct it is executed anyways.

- **TRANSMISSION IN RS 485 MODBUS** (See special manual)

- **TRANSMISSION IN RS 485 PROFIBUS** (See special manual)

- **CONTINUOUS TRANSMISSION** “ALL.Std”, “ALL.Ext and ALL.MAX” parameter
- This mode is used for interfacing to the PC, remote displays and other devices which request a constant updating of the data independently from the weight stability.
 The instrument transmits data with each converter read operation:
 - With Baud rate at 9600 one can obtain up to 10 transmissions per second.
 - With Baud rate at 4800 one can obtain up to 8 transmissions per second.
 The transmission works with weight <, =, > 0 with approved or unapproved instrument.
 The data is transmitted using the standard string (ALL.Std) or the extended string (ALL.Ext); see the “18.5 TRANSMISSION PROTOCOL” section for the description of the two strings.
 ALL.MAX transmission protocol is advisable for application in which a high frequency transmission is requested. (up to 250TX/sec with baud rate equal to 155200), the weight is transmitted in hexadecimal format (ex : 03E8 = 1.000g), without decimal point.
 Nota: the data transmission frequency is depending of the configured filter.
 To obtain 250TX/sec, you should configurate the filter to F.F.400 (SetuP-> ConFIG -> Param.-> StAbiL)

- **TRANSMISSION ON STABILITY** “StAb.St” and “StAb.EX” parameter
 Each time a weight on the scale becomes stable, a communication string is transmitted on the PC serial port.
 For non approved instruments:
 - The transmission takes place if the weight is stable and the net weight is > 10 divisions.
 - Reenabling the transmission depends on how the “rEAct” step has been set in the SET-UP environment (passage by zero of the NET weight or instability of the NET weight of 10 divisions; by choosing “always” it works upon instability).
 For approved instruments:
 - The transmission takes place if the weight is stable and the net weight is > 20 divisions.

- Reenabling the transmission depends on how the “rEAct” step has been set in the SET-UP environment (passage by zero of the NET weight or instability of the NET weight of 20 divisions; by choosing “always” it works upon instability).

The data is transmitted using the standard string (StAb.St) or the extended string (StAb.EX); see the “TRANSMISSION PROTOCOL” section for the description of the two strings

18.3 CONFIGURATION OF THE 2 SERIAL OUTPUT

PC SEL selection bidirectionnal output

CoM1 this RS485 (or RS232 output for model IPE50 Panel only, function of the position of the 3 jumpers on the PCB, RS485 in standard) is bidirectionnal (PC, PLC...), the output CoM2 RS232 serial output is unidirectionnal (printer, repeater...)

CoM2 this RS232 output is bidirectionnal (PLC ...), the output CoM1 (function of the position of the 3 jumpers on the PCB,) is unidirectionnal (printer, repeater ...)

CoM.Prn unidirectionnal output

PrModE TRANSMISSION unidirectional (RS232 or 485 depend of the PC SEL choice)

Pr- no transmission disabled.

tPr enables the printing with ASCII printer (for example DP190 or TP200).

LP542P enables to print with labelling machine LP542PLUS

ALL.Std continuous transmission with standard string.

ALL.Eht continuous transmission with extended string.

PrPC.St transmission of the standard string upon the pressing of the ENTER key.

PrPC.EH transmission of the extended string upon the pressing of the ENTER key.

NOTE: if the “TOTALIZER” mode (horizontal or vertical) is active, the transmission through the key is carried out by pressing the MODE key.

rEPE.6 transmission to 6-digit remote display IPE50.

(!) Pr-no

Nota: if the mode "totalization" is activated , the key MODE should be pressed.

bAud.Pr SET BAUD RATE

By pressing the ENTER key one accesses the selection of the data transmission speed (measured in Baud = bit/second). The possible values are: 1200, 2400, 4800, 9600, 19200, 38400, 57600, 115200.

(!) 9600

bit.Pr SET PARITY, WORD, STOP BIT

By pressing the ENTER key one accesses the selection of the available values: n-8-1, n-8-2, n-7-2, E-7-1, E-7-2.

(!) n-8-1

Prn.CtS RTS/CTS STATUS CONFIGURATION

On the printer serial line the indicator has a CTS input (Clear To Send). A device (like a printer) that is slow in processing the data received, can interrupt the transmission temporarily using this signal.

noCtS no signal

CtSL CTS active low (for LP542, TP200, DP24 printers)

CtSh CTS active high (for DP190 printers)

EmuCtS emulation of the CTS signal: one is asked to enter the number of characters (nChrS), in 3 digits, which will be transmitted to the printer upon each

transmission; then one needs to enter the waiting time in milliseconds (tiME), in 4 digits, between a transmission and another.
The TIME OUT of a printout is a minute, in other words, after a minute that the printout is blocked, it is cancelled.

NOTE: the parameter is not displayed if "Pr- no" has been selected in the "PrModE" step.
(!) noCtS

PrConF CONFIGURATION OF THE PRINTOUTS

See the "Print Programming" section for the description of all the menu's parameters.
NOTE: the parameter and all its submenus are not displayed if "Prno" has been selected in the "PWr.Prn" step or "Pr- no" in the "PrModE" step.

CoM.PC TRANSMISSION bidirectional (RS232 or 485 depend of the PC SEL choice)

PCModE TRANSMISSION SERIAL OUTPUT

ondE transmission on external command PC (given from PC or PLC, for example)
rEPE.4 *transmission to 4 digit remote display.*
rEPE.6 *transmission to 6 digit remote display IPE50.*
Prin.St. transmission of standard string when the ENTER key is pressed.
Prin.EH transmission of extended string when the ENTER key is pressed.
NOTE: if the "TOTALIZER" mode (horizontal or vertical) is active, the transmission through the key is carried out by pressing the MODE key.
485 transmission with 485 protocol, by confirming with ENTER/PRINT, one is required to enter the machine code (the message "Ad485 ou Addr" appears for an instant): enter a value between 0 and 98.
Modbus protocol MODBUS
Profi b protocol PROFIBUS (option)
ALL.Std continuous transmission with standard string.
ALL.EHt continuous transmission with extended string.
ALL.MAX quick continuous transmission
StAb.St transmission with each weigh with standard string.
StAb.EH transmission with each weigh with extended string.
For the transmission modes and protocol specifications, see the "SERIAL PORTS TRANSMISSION MODES" and "TRANSMISSION PROTOCOLS" sections.
(!) OndE

bAud SET BAUD RATE

By pressing the ENTER key one accesses the selection of the data transmission speed (measured in Baud = bit/second). The possible values are: 1200, 2400, 4800, 9600, 19200, 38400, 57600, 115200.
(!) 9600

bit SET PARITY, WORD, STOP BIT

By pressing the ENTER key, selection of the values: n-8-1, n-8-2, n-7-2, E-7-1, E-7-2.
(!) n-8-1

18.4 SERIAL COMMANDS FORMAT

Version reading command

[CC]VER<CR LF>

Instrument response:

[CC]VER,vvv,DGT<CR LF>

In which :vvv is the firmware version

Weight read command

[CC]READ<CR LF>

Instrument response: STANDARD STRING (see "TRANSMISSION PROTOCOLS" section).

Extended weight read command

[CC]REXT<CR LF>

Instrument response: EXTENDED STRING (see "TRANSMISSION PROTOCOLS" section).

Nota: in mode Transm , the instrument response is the value of each enable channel.

Ex for 2 channels : [CC]hh,pppppppp,uu,hh,pppppppp,uu + CR + LF (ex: ST, 6.000, g,ST, 20.1,kg)

In mode IND.CH with at least 2 channels validated, the instrument response the selected channel on the display, and you can change the channel with the command CGCH (see below for this command)

Extended weight read + time/date command

[CC]REXD<CR LF>

Instrument response: EXTENDED STRING (see "TRANSMISSION PROTOCOLS" section).

The unit transmit the extended stream + the date and time if the option is available

counting read command

[CC]REXTA<CR LF>

Instrument response: EXTENDED STRING for counting mode (see "TRANSMISSION PROTOCOLS" section).

Weight reading command with sensitivity times 10

[CC]GR10<CR LF>

Instrument response: STANDARD STRING : ex : ST,GX, 5.0001,kg

Reading command of microvolt relative to the weight

[CC]MVOL<CR LF>

Instrument response: STANDARD STRING : ex : ST,VT, 5.001,mV

Nota: in mode DEP.CH ou Transm, the instrument response is the value of each enable channel.

In mode IND.CH with at least 2 channels validated, the instrument response the selected channel on the display, and you can change the channel with the command CGCH (see below for this command)

Reading command of converter points relative to the weight

[CC]RAZF<CR LF>

Instrument response: STANDARD STRING . ST,RZ, 2018206,vv

Nota: If the IPE is configurated in mode IND.Ch, and at least 2 channels are connected (on channel 1 and 2) le sensor signal transmitted will be the selected channel (see command CGCH).

If the IPE is configurated in mode DEP.Ch , the value will be the sum of the connected sensors

Tare command

[CC]TARE<CR LF> or [CC]T<CR LF> (short command).

Instrument response: [CC]OK<CR LF> if the command has been RECEIVED; the instrument's response does not mean necessarily that the instrument executes the tare.

Manual tare command

[CC]TMANVVVVV<CR LF> or [CC]WVVVVV<CR LF> (short command).

VVVVVV : value of the tare with comma from 1 to 6 digits

Instrument response: [CC]OK<CR LF> if the command has been RECEIVED; the instrument's response does not mean necessarily that the instrument executes the tare.

Zero command

[CC]ZERO<CR LF> or [CC]Z<CR LF> (short command)

Instrument response: [CC]OK<CR LF> if the command has been RECEIVED; the instrument's response does not mean necessarily that the instrument executes the zero.

ESC or C command

[CC]C<CR LF>

Instrument response: [CC]OK<CR LF> if the command has been RECEIVED; the instrument's response does not mean necessarily that the instrument executes the command.

The command works also within the SET-UP environment.

Channel selection (in IND.CH mode)

[CC]CGCHN<CR LF>

Instrument response: [CC]OK<CR LF>

N: the number of the channel selected (channel that will be displayed on the IPE)

Test Command

[CC]ECHO<CR LF>

Instrument response: [CC]ECHO<CR LF>.

Setpoint command (if the option is installed)

[CC]STPTntxxxxxyyyyyy<CR LF>

in which: n indicates the SETPOINT number (1 to 6 depending of the model)

t = F if the following weight value indicates the DISABLING of the relays (OFF).

t = O if the following weight value indicates the ENABLING of the relays (ON). xxxxxx and yyyyyy take on the setpoint value of disabling or enabling: the digits must be entered WITHOUT the decimal point, omitting the NON significant zeros.

Instrument responses: [CC]OK<CR LF> in case of syntax and correct values.

[CC]NO<CR LF> in case of correct syntax but wrong values.

Note: if the setpoint is programmed without hysteresis, the value xxxxxx must be equal to yyyyyy.

Example of instrument with capacity 10,000 kg and division 1 g:

Command: STPT1F5000O6500 (Disabling relay 1 at 5 kg and enabling at 6,5 kg)

Response: OK

NOTE: An error response of the instrument happens in the following cases:

- one of the two entered values is greater than the capacity.
- one of the two entered values has a minimum division that is inconsistent in comparison to the one set in the instrument.
- the disabling value is greater than that of enabling.
- The command is wrong

NOTE: The values are available until the unit is not switched off, to record its into a non volatile memory (EEPROM) you must send the command :

[CC]CMDSAVE<CR LF>.

Instrument response: [CC]OK<CR LF>

Print Command

[CC]PRNT<CR LF> or [CC]P <CR LF> (short command).

Instrument response: [CC]OK<CR LF> if the command has been RECEIVED; the instrument's response does not mean necessarily that the instrument executes the printout.

Command for viewing temporary message on the display

[CC]DISPNNVVVVV <CR LF>

in which: NN: is the indicator display number, standard 00 (ascii hex)

VVVVVV is the message.

To cancel the message, send DISPNN or see DINT command

NOTES

In the case in which the display shown in the command is of the numeric type (for example the standard display 00), if in the transmitted message there are two consecutive points the message is stopped after the first of the two points. When the display is showing a message transmitted serially through the DISP command, the indicator does not display those messages usually shown in the scale status (ZERO, TARE, HOLD, ...).

Instrument response: [CC]OK<CR LF>

The message remains for the time set through the DINT command:

The ASCII characters having the decimal code greater than 31 are accepted.

With approved instrument:

One needs to wait the end of the current visualisation before being able to view the next one.

Command for setting display visualisation interval

[CC]DINTNNNN<CR LF>

in which: NNNN is the visualisation interval (in milliseconds), expressed in ascii hex character; for example, in order to set a visualisation time of 2 seconds (2000 milliseconds, which converted into hex it becomes 07D0), the command becomes DINT07D0<CR><LF>.

By setting a time equal to zero, the message transmitted with the DISP command remains permanently shown on the display.

Instrument response: [CC]OK<CR LF>

With approved instrument:

The minimum settable time is 1 millisecond (0001HEX), and maximum settable time is 5 seconds (5000 milliseconds, 1388 HEX).

PC confirmation command

[CC]PCOK<CR LF>

The indicator shows on the display the "-PCOK-" message for about 2 seconds.

Instrument response: [CC]OK<CR LF>.

Serial command for setting the apw (only for the counting operating mode)

[CC]SPMUvvvvvvv <CR LF> or [CC]Xvvvvvvv<CR LF> (short command).

in which: vvvvvvvv is the apw (up to 8 characters with decimal point); maximum value: 9999.999

System response: [CC]OK<CR LF>.

For example, to set a APW of 1.55 g, the command is the SPMU1.55<CR LF> or SPMU0001.550 <CR LF> and all the various combinations adding zeros to the right or to the left but taking into consideration that the maximum length of the APW field is 8 characters.

NOTES:

- The APW are not accepted in the SPMU.12<CRLF> format; these must be in the SPMU0.12<CRLF> format.
- the APW are not accepted equal to zero.

Serial command which supplies the indicator status

[CC]STAT<CR LF>

Instrument response:

[CC]STATXX<CR LF>

in which XX is a decimal value which supplies the status of the indicator; the possible values are:

XX indicator status

00 normal scale status

01 normal scale status in input

02 instrument in technical set-up

04 in boot phase

05 in rx/tx set-up phase

06 in test phase of the serial ports

07 in print test

08 in firmware update phase

09 in stand-by

10 in automatic zero phase

12 in opto-isolated inputs test phase

Key pressure simulation command

[CC]KEYPXX<CR LF>

in which XX is the code of the pressed key:

00: ->0<- key; 01: ->T<- key; 02: MODE key; 03: ENTER/PRINT key; 04: C key;

Instrument response: OK<CR LF>: accepted command.

In case the simulated key has two linked functions (key briefly pressed or at length, like the TARE key), if the KEYP command is followed by the release command of the (KEYR) key within a maximum time of 1,5 seconds, the simple function will be executed (key briefly pressed); otherwise the second function will be made (key pressed at length).

NOTA: The instrument does not transmit the OK answer to the following short commands: P, Q, T, W, X, Z.

LEGEND

[CC]= instrument code, e.g.. 00 (only with RS485 protocol).

<CR LF>= Carriage Return + Line Feed (ASCII characters 13 and 10).

SERIAL ERRORS

Upon each serial command received the instrument transmits a response which may be a response to a command (see the command description) or the indication of the command error:

ERR01<CR LF> it is shown when a correct command is transmitted from the PC to the indicator however it is followed by letters inserted involuntarily (I.E.: READF TARES...).

ERR02<CR LF> it is shown when a correct command is transmitted from the PC to the indicator, but containing wrong data.

ERR03<CR LF> it is shown when an unhallowed command is transmitted. It may be a command not used in the selected functioning mode or the command reaches the indicator in the instant in which the keyboard buffer is already occupied by another command.

ERR04<CR LF> it is shown when an inexistent command is transmitted.

18.5 TRANSMISSION PROTOCOLS

The weight data transmission on the PC and PRT serial ports may take place in two formats:

STANDARD STRING

[CC]hh,kk,pppppppp,uu + CR + LF

in which: [CC] INSTRUMENT CODE IN THE FORMAT OF TWO ASCII DECIMAL DIGITS ONLY IN THE CASE THAT THE 485 PROTOCOL IS SELECTED (FOR EXAMPLE 00).

hh	UL	Underload
	OL	Overload
	ST	Stability of the display
	US	Unstability of the display
	TL	Active inclination input
kk	NT	Net Weight
	GS	Gross Weight
	GX	Gross weight with sensitivity times 10
	VL	Value in microvolts relative to the weight
	RZ	Value in converter points relative to the weight
pppppppp	8 digits (including any sign and decimal point) which identify the weight. The insignificant digits are filled with spaces. Through the MVOL and RAZF command the indicator transmits the relative value on 10 digits instead of 8.	
Uu	Unit of measurement "kg" "bg" "bt" "lb" "mv" (microvolts) "vv" (converter points)	
CR	Carriage Return (13 ascii decimal character).	
LF	Line Feed (10 ascii decimal character).	

The transmitted weight is the GROSS weight (GS) if no TARE WEIGHT has been entered; otherwise, the NET WEIGHT (NT) will be transmitted.

EXTENDED STRING

(in response to the REXT command)

[CC]B,hh,NNNNNNNN,YYTTTTTTTT,PPPPPPPP,uu,(dd/mm/yybbhh:mm:ss"NO DATE TIME") + CR + LF

in APW mode only 1 piece counting mode or in response to the REXT command)

[CC]B,hh,NNNNNNNN,YYTTTTTTTT,PPPPPPPP,AAAAA.AAAAA,uu + CR + LF

in which: [CC] INSTRUMENT CODE IN THE FORMAT OF TWO ASCII DECIMAL DIGITS JUST IN CASE THE 485 PROTOCOL IS SELECTED (FOR EXAMPLE 00)

B scale number (1 in scale mode, 0 in pallet truck scale mode).

hh	UL	Underload
	OL	Overload
	ST	Stability of display
	US	Instability of display
	TL	Active inclination input
NNNNNNNN		net weight on 8 characters including possible sign and decimal point
YY		"PT" if the tare is manual, otherwise YY = " " (two empty spaces) if the tare is semiautomatic.
TTTTTTTT		tare weight on 8 characters including possible sign and decimal point.
PPPPPPPP		number of pieces on 8 characters, equal to 0 if the indicator is in a functioning mode other than the counting mode.
AAAAA.AAAAA		In the counting mode, 10 digits with 5 decimals
		If you the unit is not in this mode , the value is equal at 0.00000
uu		Unit of measure "Kg" " bg" " bt" "lb
dd/mm/yy		date in format date/month/year (only with REXD command if the option date or alibi memory is available)
hh:mm:ss		time in format hour:minute:second only with REXD command if the option date or alibi memory is available)
CR		Carriage Return (13 ascii decimal character)
LF		Line Feed (10 ascii decimal character)

The insignificant digits of the net, tare, gross tare weights and the pieces of the various channels will be filled with spaces (space character, 32 decimal ascii code character)

LEGEND:

b space character, 32 decimal ascii character.

19 PROGRAMMING THE PRINTOUTS

If in the set-up environment the presence of the printer has been configured correctly, the indicator carries out the print functions; each functioning mode has specific printouts, shown in the “Print examples” . In any case, it is possible to define some printing fields, the size of the characters, a heading and other options depending on the printer and the predefined functioning mode.

In the “Pr.Mode” step of the set-up environment it is possible to select whether to print on the TP200 printer or the LP542PLUS labeller; see the following steps for all the printing options.

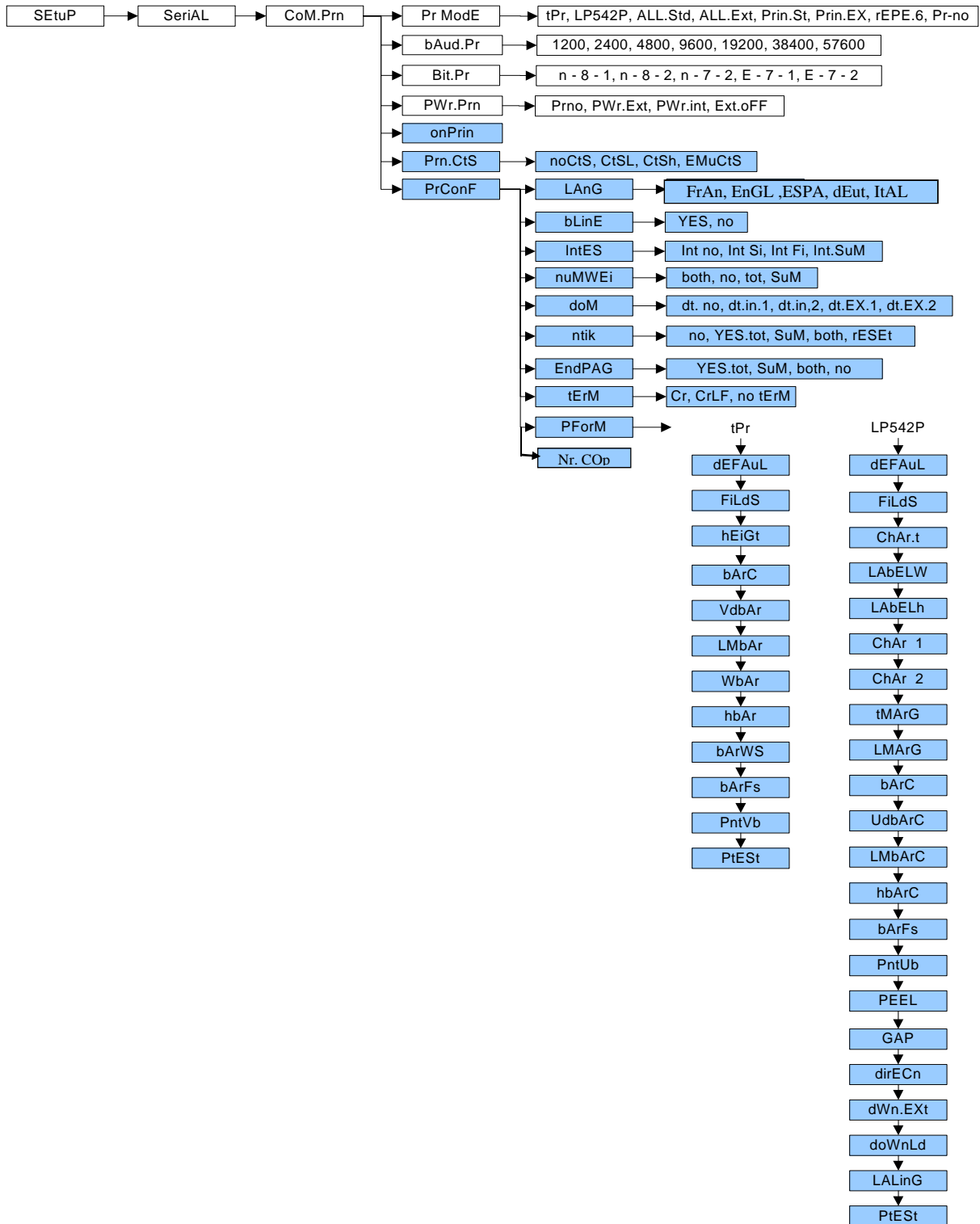

- 1) Enter the SET-UP environment of the scale (when turned on, press for an instant the ZERO or TARE key during the countdown).
- 2) Select the SETuP → Com.Prn → PrMode step and press ENTER
- 3) Select the desired printer ("tPR" or "LP542P) and press ENTER
- 4) In the "SET-UP ENVIRONMENT" section see the descriptions of the "baud.Pr", "Bit.Pr", "PWr.Prn", "on.Prin" and "Prn.CtS" steps for configuring the baud rate, the number of transmission bits, the printer's power supply and the CTS signal.
- 5) Select the "Pr Conf" step and press ENTER/PRINT: one enters the PROGRAMMING MENU OF THE PRINTOUTS. Below is the description of the steps.
- 6) Once the setting have been made, press the C key various times until the indicator shows "SAVE? In the display: confirm with ENTERto memorize and return to weighing.

PrConF CONFIGURATION OF THE PRINTOUTS

In this step one enters the print programming submenu.

NOTE: the parameter and all its submenus are not displayed unless the "Prno" parameter has been selected in the "PWr.Prn" step or "Pr- no" in the "PrModE" step.

LanG PRINTING LANGUAGE

One selects the language in which the printouts are carried out:

ItAL	italian.
EnGL	english.
dEut	german.
FrAn	french.
ESPA	spanish.

bLinE EMPTY LINE AT THE BEGINNING OF THE PRINTOUT

YES at the beginning of each printout an empty line is inserted.
 no no empty line.
 (!) YES

IntES PRINTING OF HEADING

Not available
 (!) Int no

nuMWEi PRINTING OF NUMBER OF WEIGHS (ONLY FOR TOTALIZER MODE)

no does not print the number of weighs.
 tot prints the number of weighs only in the single totalisation.
 Sum prints the number of weighs only in the partial total.
 both prints the number of weighs in the totalisations as well as in the partial total.
 NOTE: the parameter is displayed only if the "totalizer" functioning mode has been selected.
 (!) both

dOM PRINTS DATE AND TIME

dt. no	the date and time are not printed.
dt.in.1	the date and time are printed using the clock inside the printer; in the totalizer functioning mode the date and time are printed just in the total and not in the single totalizations
dt.in.2	as above, but in the totalizer functioning mode the date and time are printed also in the single totalizations.
dt.EX.1	like "dt.in.1" but the indicator's date and time board (optional) is used.

dt.EX.2 like "dt.in.2" but the indicator's date and time board (optional) is used.
NOTE: The date and time is printed, if programmed, before the possible barcode, which is always at the end of the printout
(!) dt. No

ntik PRINTS TICKET NUMBER

The ticket number is a sequence number which increases upon each printing made, this number, between 1 and 65535, is kept in memory also when the instrument is turned off.

no does not print the ticket number.

yes.tot prints the ticket number; in the totalizer functioning mode it is printed only in the single totalisations.

SuM prints the ticket number; in the totalizer functioning mode it is printed just in the partial total.

both prints the ticket number; in the totalizer functioning mode it is printed in the totalisations as well as in the partial total.

rESEt by pressing ENTER the sequence number in the ticket is zeroed.

NOTE: The ticket number, if programmed, is printed after the weight data.

(!) no

EndPAG SELECTION OF PAGE END PRINTING

This step allows to print 2 empty lines at the end of each printout (if "DP190" is selected in the "PrModE" step) or an end label (if "LP542" is selected in the "PrModE" step).

no does not print the page end

yes.tot prints the end page; in the totalizer functioning mode it is printed just in the single totalisations.

SuM prints the end page; in the totalizer functioning mode it is printed just in the partial total.

both prints the end page; in the totalizer functioning mode it is printed in the totalisations as well as in the partial total.

(!) yes.tot

tErM SETTING TERMINATOR

When connecting a printer it is often necessary to transmit one of the following protocols in order to define the end of the print line.

Cr CR (for TP200, CUSTOM, LP522/542P)

CrLF CR LF (for EPSON LX300 and TMU295).

(!) Cr

PForM PRINT FORMATTING

In this step one enters a submenu for selecting the weight data which one wants to print and the print layout.

Depending on the type of printer selected in the PrModE step (LP542P or tPr), the parameters which are suggested, change:

Nr. CoP NUMBER OF PRINTED TICKETS

Number of identical tickets printed : from 1 to 3

DEFAuL PRINTOUT DEFAULT

Through this StEP one enables the default printing relative to the selected functioning mode.

The default sets, in each of the following steps, the value marked with the (!) symbol.

FiLdS PRINTING FIELDS

Through this StEP it is possible to select which fields to be printed among those available:

G; n; t; G n; G t; n G; n t; t G, t n; G n t; G t n; n G t; n t G; t G n, t n G (in which G is the gross weight; n is the net weight and t is the tare weight).

(!) G t n

hEiGt FONT HEIGHT SELECTION FOR PRINTING THE WEIGHT DATA, DATE AND TIME, PROGRESSIVE NUMBERS AND ID'S:

ChAr 1 normal height

ChAr 2 double height

(!) ChAr 1

bArC PRINTS THE BAR CODE

In this step one programmes the printing of the 39 CODE (if "TPR" has been selected in the "PrModE" step), which will be printed before the printing of the date and time:

no does not print the bar code.

yes.tot prints the bar code; in the totalizer functioning mode it is printed just in the single totalisations.

SuM prints the bar code; in the totalizer functioning mode it is printed just in the partial total.

both prints the bar code; in the totalizer functioning mode it is printed in the totalizations as well as in the partial total.

(!) no

NOTES:

- the weight values are expressed in 6 digits without decimal point and with the possible non significant zeros present.

- between a weight value and the following one a space is inserted.

- the bar code is printed as the last data, after the weight values, possible numeric codes and ticket number, but before the date and time (with TP200 printer).

THE FOLLOWING PARAMETERS ARE VISIBLE ONLY IF IN THE PREVIOUS STEP A PARAMETER DIFFERENT FROM "no" HAS BEEN SET.

VdbAr SELECTING THE BAR CODE'S VERTICAL DISTANCE OF THE PRECEDING TEXTS:

In lines with normal height font, programmable value: 0...9. (!) 0

LMbAr SELECTION OF LEFT MARGIN

Expressed in 1/8 of a mm (from 0 to 99). (!) 00

WbAr SELECTION OF BAR CODE FONT WIDTH:

Programmable value: W1...W3
(!) W1

hbAr SELECTION OF BAR CODE FONT HEIGHT:

Expressed in 1/8 di mm (from 0 to 255) (!) 000

bArFS SELECTION OF PRINT FIELDS IN THE BAR CODE:

Programmable value:G; n; t.

In which G is gross weight, n is net weight and t is tare weighing.

(!) G

PntVb PRINTING OF THE BAR CODE'S NUMERIC FIELD

This step allows to select the printing of the bar code's numeric field:

no the numeric field is not printed.

undEr under the bar code

AboVE above the bar code

Ab/un both above as well as below the bar code.

PtEst PRINTING TEST

By pressing PRINT, a test label is printed of previously selected fields, but with fixed weight values.

The print test depends on the selected functioning mode:

STD mode: the first time the fields with the kg unit of measure are printed, the second time the fields with the lb unit of measure are printed, and so on.

NTGS, VISS, Alibi, INOUT modes: simple printing.

MASTER mode: not settable.

HOLD mode: the first time the fields without the "HOLD" message are printed, the second time the ones with the "HOLD" message are printed, and so on.

PEAk mode: the first time the fields without the "PEAK" message are printed, the second time the ones with the "PEAK" message are printed, and so on.

Tot o and tot s mode: when the PRINT is pressed a selection menu appears with the following items:

" TOT.1.0": simulates the printing of the first totalisation relative to the zero registry.

" TOT.2.0": simulates the printing of a further totalisation relative to the zero registry.

" SUM 0": simulates the printing of the partial total relative to the zero registry.

" TOT.1.1": simulates the printing of the first totalisation relative to the one registry.

" TOT.2.1": simulates the printing of a further totalisation relative to the one registry.

" SUM 1": simulates the printing of the partial total relative to the one registry.

" GtotAL": simulates the printing of the general total.

COUN mode: the first time the fields with the pieces number and apw are printed, the second time the ones without the pieces number and apw are printed.

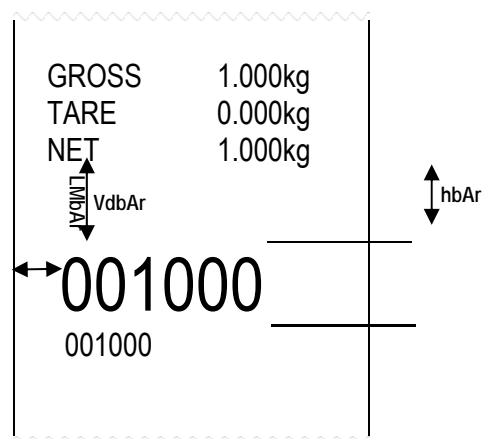

TICKET EXAMPLE

SCAIME SAS BP501 74105 ANNEMASSE	
WEIGHING NR.	00000001
GROSS	0,572 kg
TARE	0,500 kg
NET	1,500 kg
WEIGHING NR.	0000002
GROSS	3,000 kg
TARE	1,000 kg
NET	2,000 kg
WEIGHING NR.	0000002
TOTAL NET	3,500 kg
TICKET NR.	2
12:03 08-01-02	
Totalization mode	

SCAIME SAS BP501 74105 ANNEMASSE	
BRUT (HOLD)	4,664 kg
TARE (HOLD)	3,044 kg
NET (HOLD)	1,620 kg
ID1	2345
TICKET NR.	10
12:06 11-01-02	
Hold Mode	

SCAIME SAS BP501 74105 ANNEMASSE	
BRUT	8,000 kg
TARE	3,000 kg
NET	5,000 kg
TICKET NR.	11
12:41 08-01-02	
Mode (UISS, Std. ntes)	

SCAIME SAS BP501 74105 ANNEMASSE	
BRUT	1,228 kg
TARE	0,456 kg
NET	0,772 kg
PCS	150
APW	0,00514 kg
TICKET NR.	13
12:11 08-01-02	
Counting mode	

SCAIME SAS BP501 74105 ANNEMASSE	
BRUT (PEAK)	0,726 kg
TARE (PEAK)	0,000 kg
NET (PEAK)	1,606 kg
12:09 11-01-02	
Peak Mode	



Siège Social - Headquarter : Technosite Altéa - 294, Rue Georges Charpak - F.74100 JUVIGNY
 SCAIME SAS - 294, RUE GEORGES CHARPAK - CS 50501 - 74105 ANNEMASSE CEDEX
 Tél. : +33 (0)4 50 87 78 64 - Fax : +33 (0)4 50 87 78 46 - info@scaime.com - www.scaime.com
 Téléchargez tous nos documents sur notre site internet - Download all our documents on our website

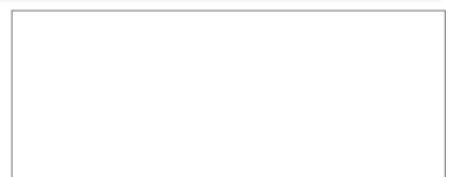

NU-IPE50-2-E-1214